



The Enchanting Douro River

Round-Trip Porto Aboard M.S. *AmaVida*

April 16–24, 2018



Dear Travelers and Friends,

Portugal's Douro River Valley, best known as the birthplace of Port wine, boasts a rich cultural history and rustic charm. Please join us next spring for a delightful voyage aboard the luxury riverboat *M.S. AmaVida*, as we cruise through verdant landscapes and explore art and architecture from the past to the present.

The Museum Travel Alliance (MTA) provides museums with the opportunity to offer their members and patrons high-end educational travel programming. Trips are available exclusively through MTA members and co-sponsoring non-profit institutions. This voyage is co-sponsored by The Metropolitan Museum of Art, the National Trust for Historic Preservation and the alumni associations of Harvard and Yale Universities, and Smith College.

Begin in Porto with a private lunch at the Serralves Foundation, home to an excellent collection of contemporary art in a building designed by a Pritzker Prize-winning architect. Then embark *AmaVida* for a seven-night cruise. Admire Baroque architecture and Flemish tapestries in Lamego and cross the border to spend a day in Salamanca, Spain. Wander the narrow streets of Castelo Rodrigo, and enjoy exclusive dinners and tastings at family-owned wine estates and a thousand-year-old monastery. Return to Porto for a private concert at Casa da Música, designed by Rem Koolhaas.

Joining us on this cruise is Nadine M. Orenstein, Drue Heinz Curator in Charge of the Department of Drawings and Prints at The Metropolitan Museum of Art. Her talks on the art history of the region will complement lectures by other distinguished experts.



For those who wish to spend more time ashore, an optional prelude in Lisbon, Portugal, and a postlude in Santiago de Compostela, Spain, are offered.

We hope to welcome you aboard in Porto next spring.

Sincerely,

A handwritten signature in blue ink that reads "Jim".

Jim Friedlander
Managing Director

CRUISE HIGHLIGHTS

SPEND seven nights exploring the stunning Douro Valley aboard a luxury river vessel

SAMPLE Vinho Verde, Port, and other local vintages at specially arranged tastings

CROSS the border into Spain to discover UNESCO-listed Salamanca, city of golden sandstone

DINE at a family-owned wine estate with cellars designed by a Pritzker Prize-winning Portuguese architect

EXPERIENCE a performance at Rem Koolhaas' Casa da Música, which according to the the *London Observer*, "explodes every preconception of what a concert hall should be"

ENJOY a private dinner overlooking the vineyard of a family-owned wine estate

The Enchanting Douro River

Round-Trip Porto Aboard M.S. *AmaVida*

April 16–24, 2018

Casa Lis, Salamanca photo by Raúl Hernández González



An optional three-night prelude in Lisbon, Portugal is offered April 13–17, 2018.

MONDAY, APRIL 16: U.S. DEPARTURE

Depart the U.S. on an overnight flight to Porto.

TUESDAY, APRIL 17: PORTO, PORTUGAL

Upon arrival, transfer to Serralves, a cultural institution whose strikingly minimalist museum of contemporary art was designed by Álvaro Siza, a Porto native and Pritzker Prize winner. Following lunch in Serralves' idyllic gardens, embark the awaiting *AmaVida*. Gather tonight for our welcome dinner. L,D

WEDNESDAY, APRIL 18: PORTO / REGUA, PORTUGAL

Be on deck this morning as *AmaVida* cruises below a magnificent iron bridge designed by Gustave Eiffel. In the afternoon, drive to Quinta da Aveleda, a family-owned wine estate with delightful gardens. Sample its Vinho Verde and enjoy a private dinner overlooking the vineyard. Tonight attend a lively onboard performance of Portuguese folk music. B,L,D

THURSDAY, APRIL 19: REGUA / BARCA D'ALVA, PORTUGAL

Lamego, nestled amid the Douro Valley's terraced slopes, is best known for its Shrine of Our Lady of Remedies, an ornate Baroque church with views of the town. Descend the church's exuberant staircase, which zigzags to the gardens below. At the Museum of Lamego, admire eclectic religious art and 16th-century Flemish tapestries, housed in a grand, 18th-century episcopal palace. Attend an onboard lecture this afternoon as *AmaVida* wends her way through the valley to Barca d'Alva. B,L,D

FRIDAY, APRIL 20: BARCA D'ALVA / VEGA DE TERRON, SPAIN

Cross the Spanish border to spend a day in UNESCO-listed Salamanca, city of golden sandstone. On a guided tour, admire the elegant university buildings and Plaza Mayor, one of the most beautiful squares in Spain. Visit the Museum of Art Nouveau and Art Deco, housed in Casa Lis, a graceful 1905 mansion with a sweeping, stained-glass façade. In Vega de Terrón, Spain, rejoin our vessel for dinner. B,L,D

SATURDAY, APRIL 21: VEGA DE TERRON / PINHAO, PORTUGAL

Spend the morning in Castelo Rodrigo, a fortified hilltop village overlooking slopes studded with almond trees and vineyards. Pass through its 16th-century walls, climb the narrow, medieval streets, and refresh with a tasting of regional wine and delicacies. A special private dinner is arranged this evening in Sabrosa at Quinta do Portal, a family-owned boutique winery with centuries-old vineyards. Tour its strikingly modern cellars, also designed by Álvaro Siza. B,L,D



Shrine of Our Lady of Remedies, photo by Trudy Lamers

SUNDAY, APRIL 22: PINHAO / REGUA / BITETOS, PORTUGAL

Call at Régua for a morning visit to the Douro Museum, housing exhibitions on the cultural heritage of the region. This afternoon *AmaVida* passes through Carrapatelo Lock, the country's first hydroelectric dam and the highest lock in Europe. Dine tonight in the Convento de Alpendurada, an 11th-century Benedictine monastery with majestic views of the valley below. As the sun sets we will see why the Portuguese named the Douro the "river of gold" (*d'ouro*). B,L,D

MONDAY, APRIL 23: BITETOS / PORTO

Return to Porto for a morning tour and private concert at Casa da Música, a landmark of 21st-century architecture

designed by Rem Koolhaas. Lunch is aboard *AmaVida*, or you may choose to lunch at leisure amid the art galleries lining Miguel Bombarda Street. This afternoon admire the beautiful views of Porto from the enchanting Crystal Palace Gardens, followed by a vintage Port tasting at W & J Graham's 1890 Lodge, a working wine cellar on a hillside above the city. Tonight the captain hosts a festive farewell dinner. B,L,D

TUESDAY, APRIL 24: PORTO / U.S. RETURN

Disembark this morning and transfer to the airport for flights home. B

An optional three-night postlude in Santiago de Compostela, Spain is offered from April 24–27, 2018.

AMAVIDA

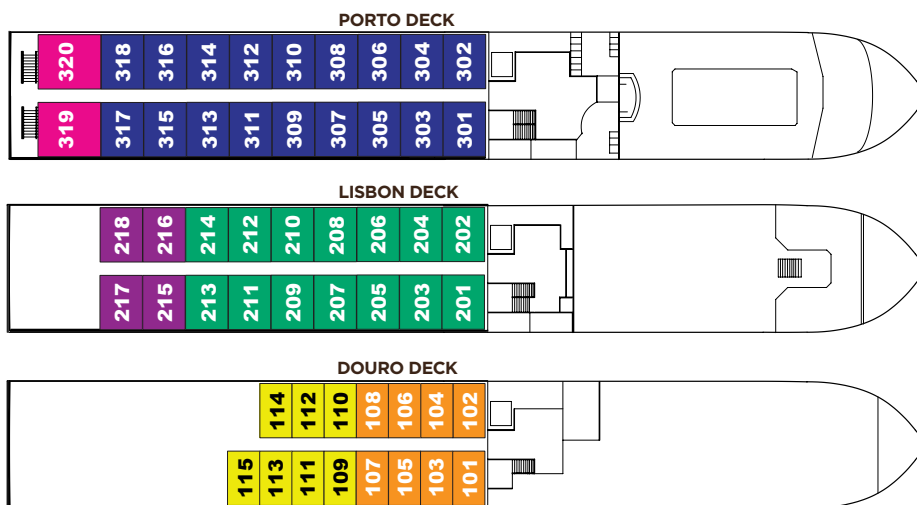

Launched in 2013, M.S. *AmaVida* brings environmentally responsible luxury cruising to the Douro River Valley. All cabins face outside and most offer balconies. Enjoy panoramic views of terraced vineyards from *AmaVida*'s sun deck, and experience gourmet dining with an *al fresco* option. Other onboard amenities include an elevator, spa, fitness center, heated pool, and complimentary internet access. The sun deck's photovoltaic solar panels provide power for the ship's operating systems, helping to preserve a pristine area that the National Geographic Society has designated a top sustainable destination. ■

CRUISE RATES

(Per Person)

Cabins	Decks	Double Rates	Single Rates
109 to 115 Panoramic window	Douro	\$6,999	\$10,499
101 to 108 Panoramic window	Douro	\$7,999	\$11,999
201 to 214 Balcony	Lisbon	\$9,999	\$17,499
215 to 218 Balcony	Lisbon	\$10,999	\$19,249
301 to 318 Balcony	Porto	\$11,999	\$23,999
319 & 320 Suite with balcony	Porto	\$15,999	Inquire

Reserve by August 31, 2017 and take \$1,000 off the per person rates below

RATES INCLUDE

- Seven nights cabin accommodations aboard *AmaVida*
- All meals as indicated in the itinerary (B=Breakfast, L=Lunch, D=Dinner); bottled water and coffee/tea with all meals, thoughtfully selected wines at lunches, dinners, and planned tastings
- Airport/pier/airport group transfers for all participants on suggested flights
- Enrichment program of lectures and talks
- Escorted sightseeing, transportation, and entrance fees for all included visits
- Customary shipboard gratuities
- Taxes and service charges; gratuities to guides and drivers

NOT INCLUDED IN RATES International airfare; passport fees; meals not specified; alcoholic beverages other than wine at lunches, dinners, and planned tastings; personal items and expenses; airport transfers for those not on suggested flights; trip insurance; optional Lisbon prelude or Santiago de Compostela postlude; any other items not specifically mentioned as included.

AmaVida in Porto





Serralves, photo by Vanessa Fermino

**THE MUSEUM TRAVEL ALLIANCE
THE ENCHANTING DOURO RIVER ▪ APRIL 16-24, 2018
RESERVATION FORM**

To reserve a place, please call The Museum Travel Alliance at 212-302-3251 or 855-533-0033, fax: 212-344-7493; or complete and return this form with your deposit of \$1,000 per person (of which \$500 is non-refundable for administrative fees) payable to The Museum Travel Alliance. Mail to: *The Museum Travel Alliance*, 1040 Avenue of the Americas, 23rd floor, New York, NY 10018-3721.

Name(s) in full as on passport(s). Please print.

Address

City _____ State _____ Zip _____

Telephone (home) _____ (business) _____

Fax _____ E-mail _____

ACCOMMODATIONS

AmaVida cabin preference (1) _____ (2) _____

I wish to share a cabin with _____

OPTIONAL PRELUDE & OPTIONAL POSTLUDE

- I/We would like to join the optional prelude in Lisbon, Portugal
- I/We would like to join the optional postlude in Santiago de Compostela, Spain

Hotel Room Preference One bed Two beds Single

MTA MUSEUM AFFILIATION _____

FORM OF PAYMENT

- Enclosed is my check (payable to *The Museum Travel Alliance*)
- Debit card
- Credit card

Name on debit/credit card

Debit/credit card number

3- or 4-digit security code _____ Expiration date _____

I/We confirm that I/we have carefully read and agree to the *Terms & Conditions* of this Program (see www.museumtravelalliance.com/terms.php to review or call for a copy). I/We agree to full payment 120 days prior to departure. Each participant must sign below.

Signature (required) _____ Date _____

Signature (required) _____ Date _____